

Features

- Mount directly to spring return actuators with NAMUR interface
- Same poppet valve performance as in standard 8320 valves
- Integral breather block prevents ingestion of contaminants or corrosives
- Variety of flow and pressure ratings
- Mountable in any position

Construction

Valve Parts in Contact with Fluids		
Body	Brass	303 Stainless Steel
Seals and Discs	NBR	
Core Tube	305 Stainless Steel	
Core and Plugnut	430F Stainless Steel	
Core Springs	302 Stainless Steel	
Shading Coil	Copper	Silver
Disc-Holder	CA	
Core Guide	CA (10.1 and 17.1 watts only)	

Electrical

Standard Coil and Class of Insulation	Watt Rating and Power Consumption				Spare Coil Part Number			
	DC Watts	AC			General Purpose		Explosionproof	
		Watts	VA Holding	VA Inrush	AC	DC	AC	DC
F	10.6	6.1	16	30	238210	238310	238214	238314
F	11.6	10.1	25	50	238610	238710	238614	238714
F	22.6	17.1	40	70	238610	238710	238614	238714

Standard Voltages: 24, 120, 240, 480 volts AC, 60 Hz (or 110, 220 volts AC, 50 Hz). 6, 12, 24, 120, 240 volts DC. Must be specified when ordering.
Other voltages are available when required.

Special Construction: Dual solenoid construction for redundant controls and dribble control available. Consult your local ASCO sales office for details.

Solenoid Enclosures

Standard: Watertight, Types 1, 2, 3, 3S, 4, and 4X.

Optional: Explosionproof and Watertight, Types 3, 3S, 4, 4X, 6, 6P, 7, and 9. (To order, add prefix "EF" to catalog number.)

See *Optional Features Section* for other available options.

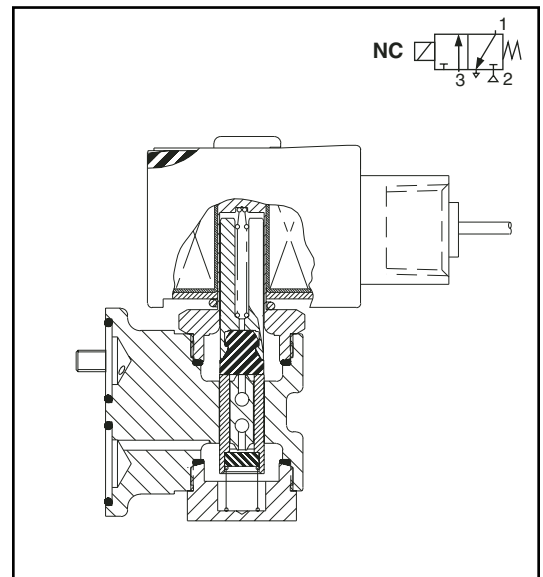
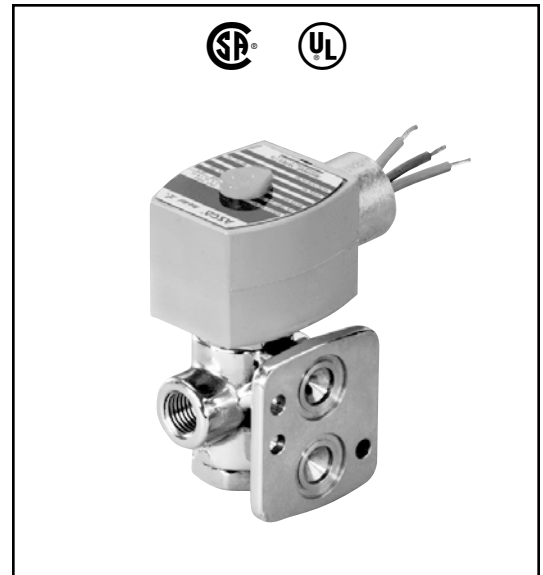

VALVE
AUTOMATION

Nominal Ambient Temp. Ranges

AC: 0°F to 125°F (-18°C to 52°C)

DC: 0°F to 104°F (-18°C to 40°C)

When used at temperatures below 32°F (0°C), media must be moisture free. Also available: -40° construction. Please contact ASCO sales office for details.

Approvals

UL component and CSA certified.

SIL 3 capable per IEC 61508.

Third party certification provided by EXIDA.

Refer to *Engineering Section* for details.

Specifications (English units)

Pipe Size (in)	Orifice Size (in)	Cv Flow Factor	Operating Pressure Differential (psi)		Max. Fluid Temp. °F		Brass Body Catalog Number	Stainless Steel Body Catalog Number	Const. Ref.	Watt Rating/Class of Coil Insulation	
			Air-Inert Gas		AC	DC				AC	DC
			Max. AC	Max. DC	AC	DC	AC	DC			
NORMALLY CLOSED (Closed when de-energized) – PFD_{AVG} = 6.81 x 10⁻⁴											
1/4	1/16	.09	150	125	180	120	8320G701	8320G711	1	6.1/F	10.6/F
1/4	3/32	.12	100	100	180	120	8320G702	8320G712	1	6.1/F	10.6/F
1/4	1/16	.09	210	160	180	120	8320G703	8320G713 ①	2	17.1/F	11.6/F
1/4	3/32	.12	150	150	180	120	8320G704	8320G714 ①	2	10.1/F	22.6/F
1/4	1/8	.21	100	-	180	-	8320G705	8320G715 ①	2	17.1/F	-

① Standard ambient temperature rating of -40°F.

Specifications (Metric units)

Pipe Size (in)	Orifice Size (mm)	Kv Flow Factor (m³/h)	Operating Pressure Differential (bar)		Max. Fluid Temp. °C		Brass Body Catalog Number	Stainless Steel Body Catalog Number	Const. Ref.	Watt Rating/Class of Coil Insulation	
			Air-Inert Gas		AC	DC				AC	DC
			Max. AC	Max. DC	AC	DC	AC	DC			
NORMALLY CLOSED (Closed when de-energized) – PFD_{AVG} = 6.81 x 10⁻⁴											
1/4	2	.08	10	9	81	48	8320G701	8320G711	1	6.1/F	10.6/F
1/4	2	.10	7	7	81	48	8320G702	8320G712	1	6.1/F	10.6/F
1/4	2	.08	14	11	81	48	8320G703	8320G713 ①	2	17.1/F	11.6/F
1/4	2	.10	10	10	81	48	8320G704	8320G714 ①	2	10.1/F	22.6/F
1/4	3	.18	7	-	81	-	8320G705	8320G715 ①	2	17.1/F	-

① Standard ambient temperature rating of -40°C.

Dimensions inches (mm)

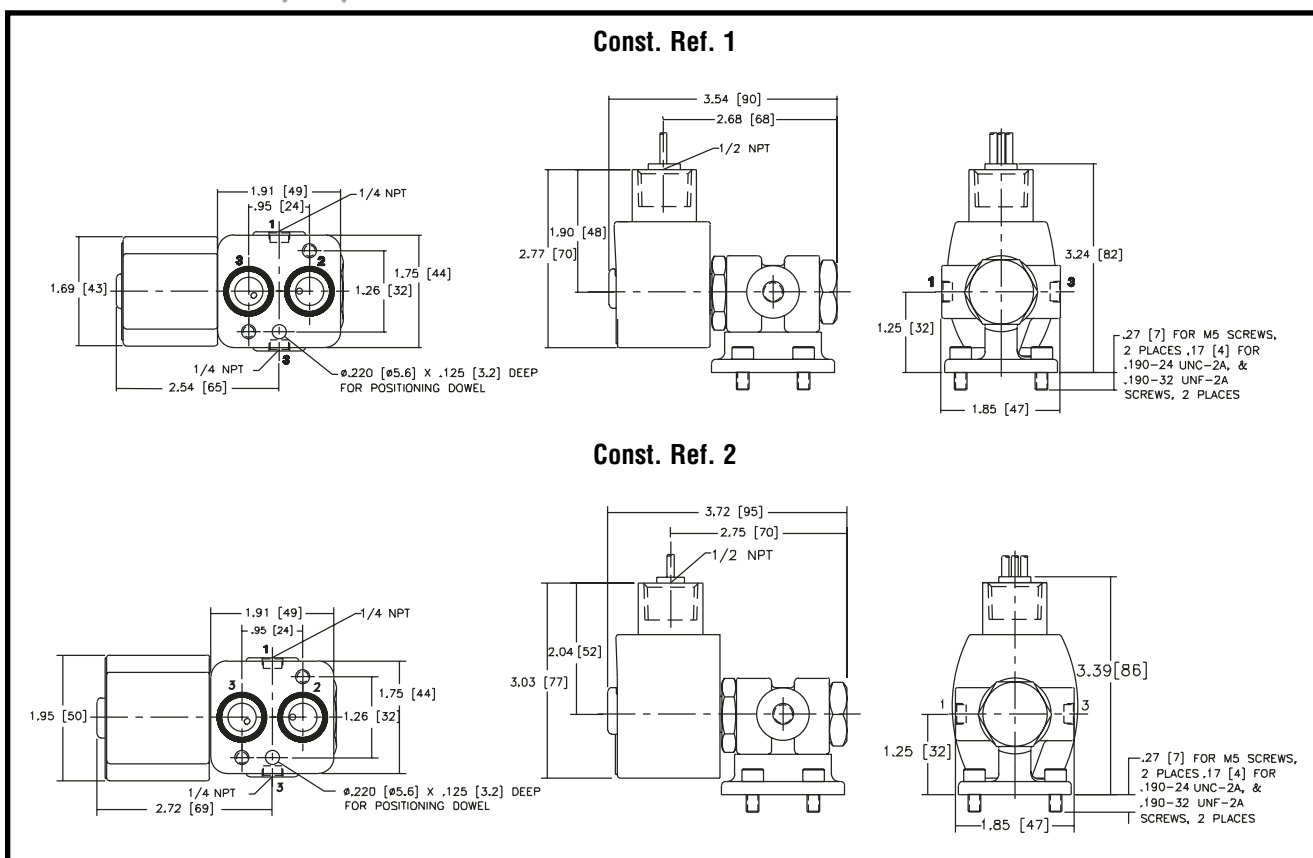

VALVE
AUTOMATION



Butler & Land Technologies

Butler & Land, Inc. is a manufacturer representative and distributor with extensive experience in the distribution and application of electrical equipment, instrumentation, controls and sensors to industrial and utility providers for over 70 years. Some of the industries we provide service to include, but are not limited to; food/beverage, water utilities, refineries, petrochemical plants, OEM's and electrical utilities.

www.butlerandland.com

Dallas, Texas

214-343-8800

10823 Sanden Dr, Dallas, TX 75238

Houston, Texas

713-896-0808

10900 Brittmoore Park Dr J, Houston, TX 77041

New Orleans, Louisiana

504-734-8888

1508 Edwards Ave. Suite GG, Harahan, LA 70123