



ASCO™ Solenoid Valves

3 way, NC/NO/U, Direct Operated, 1/8" or 1/4" Tapped

3/2
Series
356

Features & Benefits

- Wide range of flow and pressure ratings
- Quick disassembly of core tube for easy maintenance of internal parts
- Standard disc seal made of FPM, EPDM, NBR suitable for a wide range of operating temperatures and compatible with many fluids
- Standard manual operator allows an easy installation (1/8" version only)
- AC/DC interchangeability of the solenoid without disassembly of the valve (1/8" version only)
- UL429 and EN 60335 certified
- NSF 169 and EC 1935 / 2004 certified see "15-DIGIT PRODUCT CODE"
- Compact and low weight valve
- The solenoid valves satisfy all relevant EU and EAC directives

General

Differential pressure See «SPECIFICATIONS» [1 bar = 100 kPa]
Ambient temperature range -10°C to +60°C (14°F to 140°F)
Maximum viscosity 40 cSt (mm²/s)
Response time 10 - 30 ms

fluids (*)	temperature range (TS) ⁽¹⁾	seal materials (*)
air, inert gas, water, oil hot water and steam ⁽²⁾	0°C to +130°C (32°F to 266°F)	FPM (fluoroelastomer)
air, inert gas, water hot water and steam ⁽²⁾	-10°C to +140°C (14°F to 284°F)	EPDM (ethylene propylene diene monomer)
air, inert gas, water, oil	-10°C to +90°C (14°F to 194°F)	NBR (nitrile)

Materials in contact with fluid

(*) Ensure that the compatibility of the fluids in contact with the materials is verified

Body Brass or stainless steel, AISI 316
Shading coil Copper
Core tube Stainless steel
Core and plugnut Stainless steel
Springs Stainless steel
Seal & Disc FPM or EPDM or NBR
Seat Brass or Stainless Steel AISI 303

Electrical characteristics

Coil insulation class F (H - approval pending)
Connector Spade plug (cable Ø 6-8 mm or Ø 6-10 mm)
Connector specification DIN 43650, 11 mm, industry standard B (type 01) or ISO 4400 / EN 175301-803, form A (type 02)
Electrical safety IEC 335
Electrical enclosure protection Moulded IP67 (EN 60529) with plug-connector
Standard voltages DC (=) : 12 - 24V (+10% -5%)
 AC (~) : 24V/50-60 Hz - 110V/50 Hz (120 V/60Hz)
 230V/50-60 Hz (+10% -15%)

operator ambient temperature range (TS) °C (°F)	power ratings		replacement coil			Type
	holding ~ (VA)	hot/cold = (W)	~		= 24 V DC	
			120 V/60 Hz 110 V/50 Hz	230 V /50-60 Hz		
-10 to +60 (14 to 140)	4.5	3	533534-024	533534-003	-	01
	-	-	-	-	533534-002	
	14	9	533593-020	533593-003	533593-002	

Options

- NSF 169, EC 1935 / 2004 approval, EPDM/FPM disc and seal (Food Grade)

(*) Ensure that the compatibility of the fluids in contact with the materials is verified.

- ⁽¹⁾ The minimum ambient temperature of the solenoid valve is determined by the limitations of minimum temperature indicated.
⁽²⁾ Steam only for 1/4" version with stainless steel seat or body.

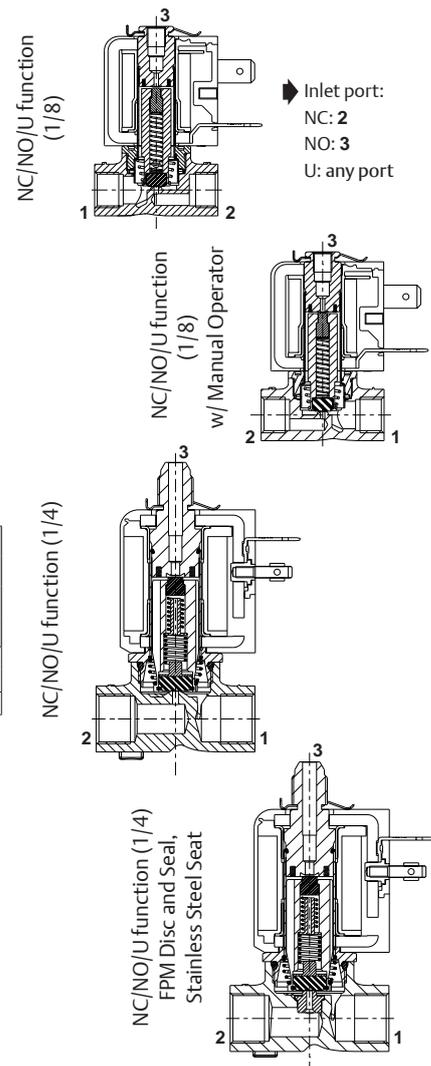
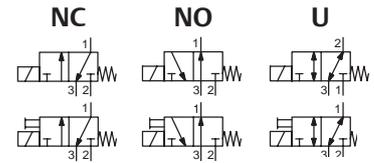

01530CB-2020/R01 Availability, design and specifications are subject to change without notice. All rights reserved.

Specifications ⁽¹⁾

Specifications ⁽¹⁾															15-DIGIT PRODUCT CODE								
pipe size	orifice size	flow coefficient Kv		operating pressure differential bar (psi)						power coil (W)		thread type	dimensions / type ⁽²⁾	brass	stainless steel	options		voltage code					
				max. (PS)												without manual operator	with manual operator	230 V/50-60 Hz	110 V/50 Hz (120 V / 60 Hz)	24 V/50-60 Hz	12 V/DC	24 V/DC	
				air (*)		water (*)		oil (*)															
				~	=	~	=	~	=														
mm (in)	m ³ /h (Cv)	l/min	min.	~	=	~	=	~	=	~	=	~	=	~	=	~	=						
NC - Normally closed, FPM disc and seal																							
1/8	1.2 (3/64)	0.05 (0.06)	0.83	0	15 (218)	-	15 (218)	-	15 (218)	-	3	-	G	01	G356C134S1	G356C144S1	V00	V01	FH	F0	FQ	F3	F1
					-	15 (218)	-	15 (218)	-	15 (218)	-	5	G	01	G356C149S1	G356C159S1							
					-	15 (218)	-	15 (218)	-	15 (218)	-	5	NPT	01	8356C149S1	8356C159S1							
					-	15 (218)	-	15 (218)	-	15 (218)	-	5	NPT	01	8356C149S1	8356C159S1							
	1.6 (1/16)	0.08 (0.09)	1.33	0	10 (145)	-	10 (145)	-	10 (145)	-	3	-	G	01	G356C135S1	G356C145S1							
					-	10 (145)	-	10 (145)	-	10 (145)	-	5	G	01	G356C150S1	G356C160S1							
					-	10 (145)	-	10 (145)	-	10 (145)	-	5	NPT	01	8356C150S1	8356C160S1							
					-	10 (145)	-	10 (145)	-	10 (145)	-	5	NPT	01	8356C150S1	8356C160S1							
	2 (5/64)	0.1 (0.12)	1.67	0	6 (87)	-	6 (87)	-	6 (87)	-	3	-	G	01	G356C136S1	G356C146S1							
					-	6 (87)	-	6 (87)	-	6 (87)	-	5	G	01	G356C151S1	G356C161S1							
					-	6 (87)	-	6 (87)	-	6 (87)	-	5	NPT	01	8356C151S1	8356C161S1							
					-	6 (87)	-	6 (87)	-	6 (87)	-	5	NPT	01	8356C151S1	8356C161S1							
2.4 (3/32)	0.13 (0.15)	2.17	0	4 (58)	-	4 (58)	-	4 (58)	-	3	-	G	01	G356C137S1	G356C147S1								
				-	4 (58)	-	4 (58)	-	4 (58)	-	5	G	01	G356C152S1	G356C162S1								
				-	4 (58)	-	4 (58)	-	4 (58)	-	5	NPT	01	8356C152S1	8356C162S1								
				-	4 (58)	-	4 (58)	-	4 (58)	-	5	NPT	01	8356C152S1	8356C162S1								
1/4 ⁽³⁾	1.6 (1/16)	0.08 (0.09)	1.33	0	13 (189)		13 (189)		13 (189)		9	9	G*	02	G356C119S1	G356C127S1							
					8 (116)		8 (116)		8 (116)		9	9	NPT	02	8356C119S1	8356C127S1							
	2.4 (3/32)	0.15 (0.17)	2.50	0	3 (44)		5 (72)		3 (44)		5 (72)	9	9	G*	02	G356C123S1	G356C131S1						
					2.5 (36)		3 (43)		2.5 (36)		3 (43)	9	9	NPT	02	8356C123S1	8356C131S1						
	4.5 (11/64)	0.4 (0.46)	6.67	0	2.5 (36)		3 (43)		2.5 (36)		3 (43)	9	9	G*	02	G356C124S1	G356C132S1						
					2.5 (36)		3 (43)		2.5 (36)		3 (43)	9	9	NPT	02	8356C124S1	8356C132S1						
	NO - Normally open, FPM disc and seal																						
	1/8	1.6 (1/16)	0.07 (0.08)	1.17	0	8.5 (123)	-	8.5 (123)	-	8.5 (123)	-	3	-	G	01	G356C223S1	G356C235S1						
-						8.5 (123)	-	8.5 (123)	-	8.5 (123)	-	5	G	01	G356C227S1	G356C239S1							
-						8.5 (123)	-	8.5 (123)	-	8.5 (123)	-	5	NPT	01	8356C227S1	8356C239S1							
1/4 ⁽³⁾	2.4 (3/32)	0.15 (0.17)	2.50	0	9 (130)	9 (130)	9 (130)	9 (130)	9 (130)	9 (130)	9	9	G	02	G356C214S1	G356C219S1							
					9 (130)	9 (130)	9 (130)	9 (130)	9 (130)	9 (130)	9	9	NPT	02	8356C214S1	8356C219S1							

⁽¹⁾ All performances are referred to Ambient Temperature = +60°C.
⁽²⁾ For dimensions, see drawing(s) for each construction type on the following page(s).
⁽³⁾ Steam: . EPDM Sealing PS max. 4 bar (max. temperature of fluid 140°C)
. FPM Sealing PS max. 2.8 bar (max. temperature of fluid 130°C)
(*) Ensure that the compatibility of the fluids in contact with the materials is verified.

Specifications ⁽¹⁾

														15-DIGIT PRODUCT CODE								
pipe size	orifice size	flow coefficient Kv		operating pressure differential bar (psi)						power coil (W)		thread type	dimensions / type ⁽²⁾	brass	stainless steel	options		voltage code				
				max. (PS)												without manual operator	with manual operator	230 V/50-60 Hz	110 V/50 Hz (120 V / 60 Hz)	24 V/50-60 Hz	12 V/DC	24 V/DC
				air (*)		water (*)		oil (*)														
mm (in)	m ³ /h (Cv)	(l/min)	min.	~	=	~	=	~	=	~	=											
U - Universal, FPM disc and seal																						
1/8	1.2 (3/64)	0.05 (0.06)	0.83	0	7 (102)	-	7 (102)	-	7 (102)	-	3	-	G 01	G356C312S1	G356C316S1	V00	V01	FH	FO	FQ	F3	F1
					-	7 (102)	-	7 (102)	-	7 (102)	-	5	G 01	G356C320S1	G356C324S1							
					-	7 (102)	-	7 (102)	-	7 (102)	-	5	NPT 01	8356C320S1	8356C324S1							
					-	7 (102)	-	7 (102)	-	7 (102)	-	5	NPT 01	8356C320S1	8356C324S1							
	1.6 (1/16)	0.08 (0.09)	1.33	0	4.5 (65)	-	4.5 (65)	-	4.5 (65)	-	3	-	G 01	G356C313S1	G356C317S1							
					-	4.5 (65)	-	4.5 (65)	-	4.5 (65)	-	5	G 01	G356C321S1	G356C325S1							
					-	4.5 (65)	-	4.5 (65)	-	4.5 (65)	-	5	NPT 01	8356C321S1	8356C325S1							
					-	4.5 (65)	-	4.5 (65)	-	4.5 (65)	-	5	NPT 01	8356C321S1	8356C325S1							
	2 (5/64)	0.1 (0.12)	0.83	0	3 (44)	-	3 (44)	-	3 (44)	-	3	-	G 01	G356C314S1	G356C318S1							
					-	3 (44)	-	3 (44)	-	3 (44)	-	5	G 01	G356C322S1	G356C326S1							
					-	3 (44)	-	3 (44)	-	3 (44)	-	5	NPT 01	8356C314S1	8356C318S1							
					-	3 (44)	-	3 (44)	-	3 (44)	-	5	NPT 01	8356C322S1	8356C326S1							
2.4 (3/32)	0.13 (0.15)	2.17	0	2 (29)	-	2 (29)	-	2 (29)	-	3	-	G 01	G356C315S1	G356C319S1								
				-	2 (29)	-	2 (29)	-	2 (29)	-	5	G 01	G356C323S1	G356C327S1								
				-	2 (29)	-	2 (29)	-	2 (29)	-	5	NPT 01	8356C315S1	8356C319S1								
				-	2 (29)	-	2 (29)	-	2 (29)	-	5	NPT 01	8356C323S1	8356C327S1								
1/4 ⁽³⁾	2.4 (3/32)	0.15 (0.17)	2.50	0	5 (72.5)	5 (73)	5 (72.5)	5 (73)	5 (72.5)	5 (73)	9	9	G 02	G356C303S1	G356C309S1	V00	-	FH	FO	FQ	F3	F1
					-	5 (73)	-	5 (73)	-	5 (73)	-	9	NPT 02	8356C303S1	8356C309S1							

⁽¹⁾ All performances are referred to Ambient Temperature = +60°C.

⁽²⁾ For dimensions, see drawing(s) for each construction type on the following page(s).

⁽³⁾ Steam: . EPDM Sealing PS max. 4 bar (max. temperature of fluid 140°C)

. FPM Sealing PS max. 2.8 bar (max. temperature of fluid 130°C)

(*) Ensure that the compatibility of the fluids in contact with the materials is verified.

Product selection guide

Configurator - CAD Files

PRODUCT CODE

G 356 C 134 S1 V00 F1

Connection Type
G = ISO 228/1 (1/8" or 1/4")
8 = NPT (SAE 71051)

Product series
356

Revision letter
C = Initial release

Valves version

Electrical interface
S1 = With spade plug connector
S0 = Without spade plug connector
L0 = Leaded coil (1/8" - 1/4", 500 mm cable length)

Voltage

- F1** = 24 V DC Class F
- F3** = 12 V DC Class F
- FQ** = 24 V / 50-60 Hz Class F
- F0** = 110 V / 50 Hz (120 V / 60 Hz) Class F
- FH** = 230 V / 50-60 Hz Class F
- ET** = 220-230 V / 50 Hz 208-240 V / 60 Hz Class F ⁽¹⁾
- H1** = 24 V DC Class H
- HH** = 230 V / 50-60 Hz Class H

Options

Without manual operator

- E00** = EPDM Disc and Seal
- V00** = FPM Disc and Seal
- N00** = NBR Disc and Seal
- 9CK** = EPDM Disc and Seal (Food Grade) + NSF + EC 1935 / 2004
- 9CM** = FPM Disc and Seal (Food Grade) + NSF + EC 1935 / 2004
- 9DF** = EPDM Disc and Seal (Food Grade) + Stainless Steel Seat + NSF + EC 1935 / 2004 ⁽²⁾
- 9DH** = FPM Disc and Seal (Food Grade) + Stainless Steel Seat + NFS + EC 1935 / 2004 ⁽²⁾
- 9DP** = EPDM Disc and Seal + Stainless Steel Seat ⁽²⁾
- 9DQ** = FPM Disc and Seal + Stainless Steel Seat ⁽²⁾

With manual operator ⁽³⁾

- (With maintained manual operator)
- E01** = EPDM Disc and Seal, w/ Manual Operator
- V01** = FPM Disc and Seal, w/ Manual Operator
- N01** = NBR Disc and Seal, w/ Manual Operator
- 9CE** = EPDM Disc and Seal (Food Grade), w/ Manual Operator + NSF + EC 1935 / 2004
- 9CW** = FPM Disc and Seal (Food Grade), w/ Manual Operator + NSF + EC 1935 / 2004

⁽¹⁾ To obtain the correct pressure rating and power absorption check the landing pages of the online configurator. Operating Voltage Range (+10% -10%).

⁽²⁾ Only for 1/4" Version.

⁽³⁾ Not available for 1/4" Version.

Repair Kits and Service Parts - Spare Parts Kits

		Spare parts kits no. (*)							
		EPDM Disc and Seal	FPM Disc and Seal	NBR Disc and Seal	-	-	-	-	-
NC - Normally closed - 1/4" - AC (~) / DC (=)									
356C119/121/123/124/ 127/129/131/132	M200708	E00	V00	N00	-	-	-	-	-
NO - Normally open - 1/4" - AC (~) / DC (=)									
356C214/219	M200710	E00	V00	N00	-	-	-	-	-
U - Universal - 1/4" - AC (~) / DC (=)									
356C301/303/305/ 307/309/311	M200712	E00	V00	N00	-	-	-	-	-
		EPDM Disc and Seal (Food Grade) + NSF + EC 1935 / 2004 + Stainless Steel Seat	FPM Disc and Seal (Food Grade) + NSF + EC 1935 / 2004 + Stainless Steel Seat	EPDM Disc and Seal (Food Grade) + NSF + EC 1935 / 2004	FPM Disc and Seal (Food Grade) + NSF + EC 1935 / 2004	EPDM Disc and Seal + Stainless Steel Seat	FPM Disc and Seal + Stainless Steel Seat		
NC - Normally closed - 1/4" - AC (~) / DC (=)									
356C119/121/123/124/ 127/129/131/132	M200708	9DF	9DH	9CK	9CM	9DP	9DQ		
NO - Normally open - 1/4" - AC (~) / DC (=)									
356C214/219	M200710	9DF	9DH	9CK	9CM	9DP	9DQ		
U - Universal - 1/4" - AC (~) / DC (=)									
356C301/303/305/ 307/309/311	M200712	9DF	9DH	9CK	9CM	9DP	9DQ		

01530GB-2020/R01
Availability, design and specifications are subject to change without notice. All rights reserved.

Installation

- The solenoid valves can be mounted in any position without affecting operation
- Solenoid valves have 2 mounting holes in body
- Thread connection “G” applicable for 1/8, have standard thread according to ISO 228/1
- Thread connection “8” have standard thread = NPT (SAE 71051)
- Installation/maintenance instructions are included with each valve

Dimensions mm (inches), Weight kg (Lbs)

Configurator - CAD Files



TYPE 01

Electrical interface “S1”
Coil size 20 mm - Thermoplastic moulded
IEC 335 / DIN 43650
IP67

NC (1/8”) - Without manual operator (V0)

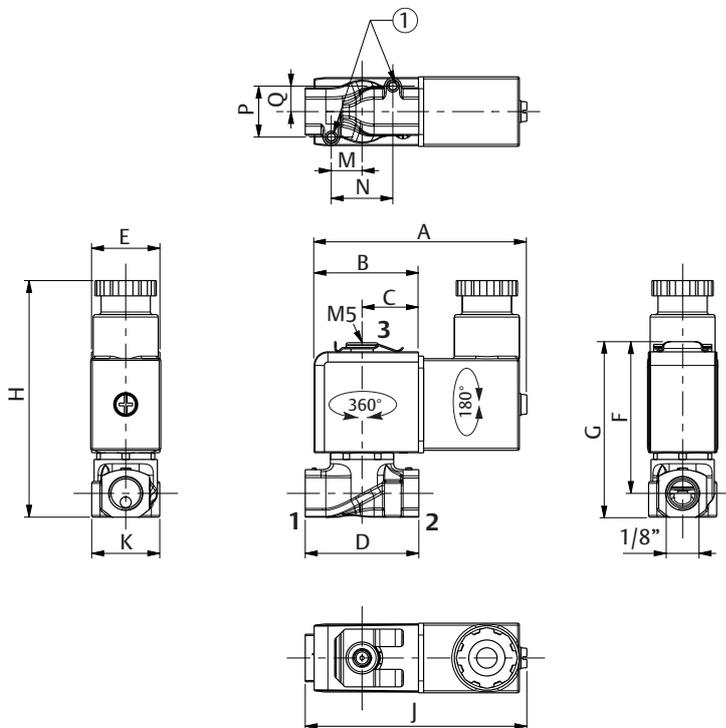

➤ Inlet port:
NC: 2
NO: 3
U: any port

① 2 mounting holes:
M3 dia., through holes (0.12 inch dia.)

size 20		A	B	C	D	E	F	G	H	J	K	M	N	P	Q	weight ⁽¹⁾	
G356C134..G356C162	mm	61.9	30.5	16.5	33.2	20	44.7	51.7	69.7	64.8	19.9	9	18	15	7.5	0.155	kg
G356C223..G356C239																	
G356C312..G356C323																	
8356C134..8356C162	(in)	2.44	1.20	0.65	1.31	0.79	1.76	2.03	2.74	2.55	0.78	0.35	0.71	0.59	0.30	0.34	(Lbs)
8356C223..8356C239																	
8356C312..8356C323																	

⁽¹⁾ Incl. coil(s) and connector(s).

Dimensions mm (inches), Weight kg (Lbs)

Configurator - CAD Files

NC (1/8") - With manual operator (V1)

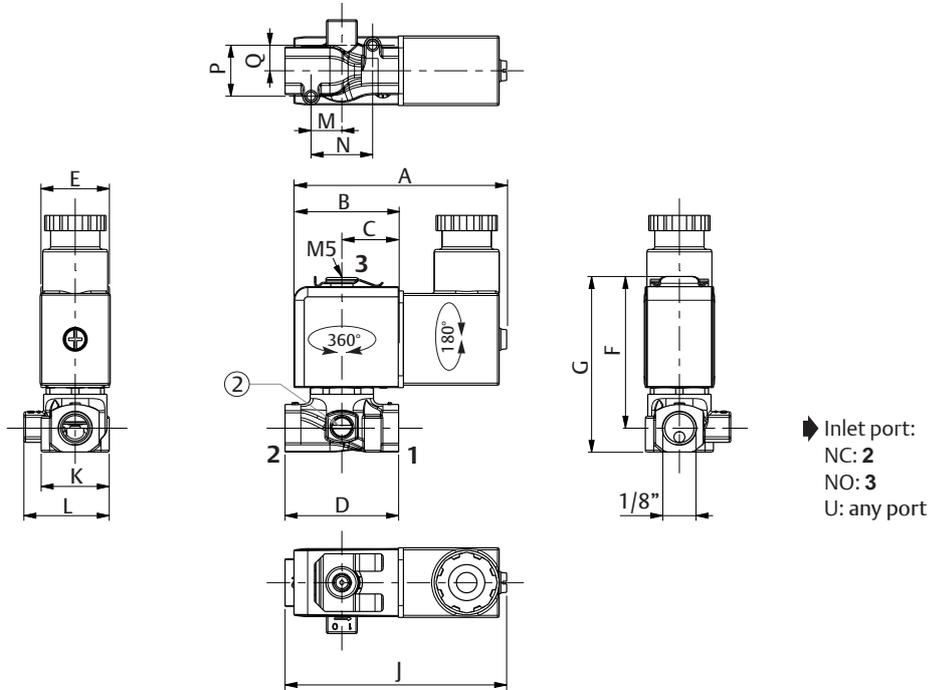

- ① 2 mounting holes:
M3 dia., through holes (0.12 inch dia.)
- ② Manual operator location

size 20		A	B	C	D	E	F	G	H	J	K	L	M	N	P	Q	weight ⁽¹⁾	
G356C134..G356C162	mm	61.9	30.5	16.5	33.2	20	44.7	51.7	69.7	64.8	19.9	24.95	9	18	15	7.5	0.155	kg
G356C223..G356C239																		
G356C312..G356C323																		
8356C134..8356C162	(in)	2.44	1.20	0.65	1.31	0.79	1.76	2.03	2.74	2.55	0.78	0.98	0.35	0.71	0.59	0.30	0.34	(Lbs)
8356C223..8356C239																		
8356C312..8356C323																		

⁽¹⁾ Incl. coil(s) and connector(s).

Dimensions mm (inches), Weight kg (Lbs)

Configurator - CAD Files



TYPE 02

Electrical interface "S1"
Coil size 30 mm - Thermoplastic moulded
IEC 335 / ISO 4400
IP67

NC (1/4") - Without manual operator (V0)

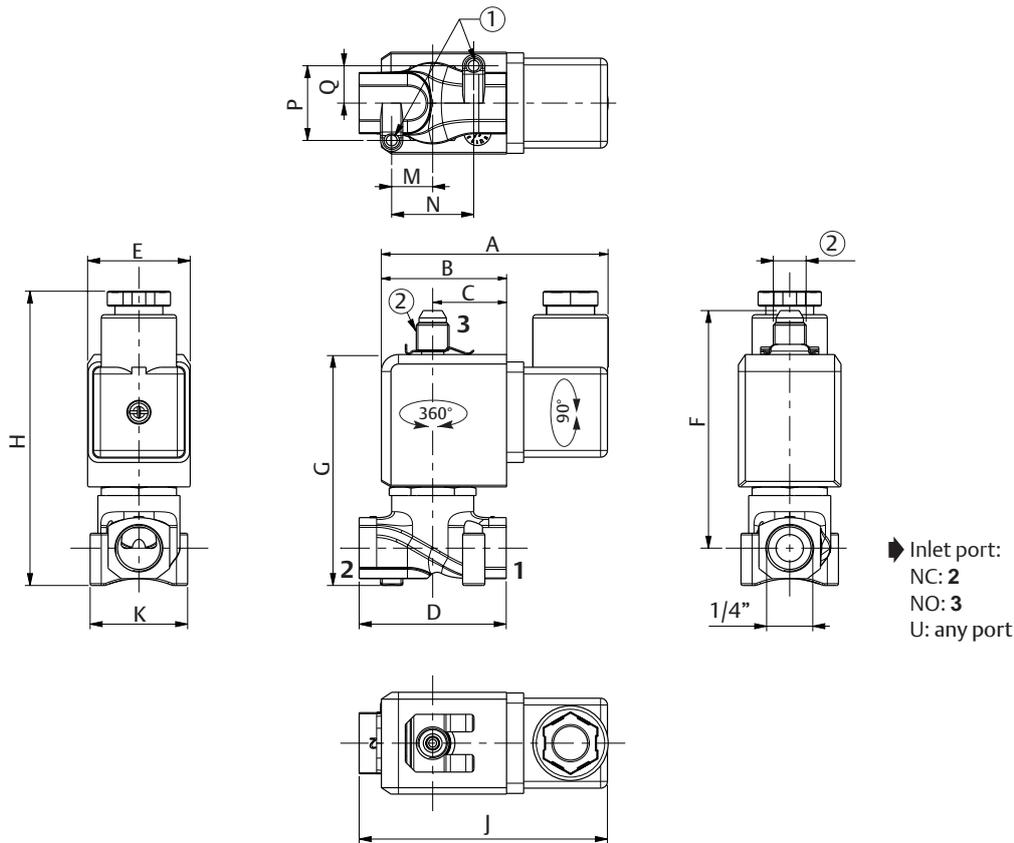

- ① 2 mounting holes:
M4 dia., through holes (0.16 inch dia.)
- ② 1/8" threaded

size 30		A	B	C	D	E	F	G	H	J	K	M	N	P	Q	weight ⁽¹⁾	
G356C119..G356C132 G356C214 / G356C219 G356C303 / G356C309	mm	66.3	36.6	21.6	43	30	70	81	86.7	72.6	28.5	12	24	22	11	0.3	kg
8356C119..8356C132 8356C214 / 8356C219 8356C303 / 8356C309	(in)	2.61	1.44	0.85	1.69	1.18	2.75	3.18	3.41	2.86	1.12	0.47	0.94	0.87	0.43	0.66	(Lbs)

⁽¹⁾ Incl. coil(s) and connector(s).

01530GB-2020/R01
Availability, design and specifications are subject to change without notice. All rights reserved.

Dimensions mm (inches), Weight kg (Lbs)

Configurator - CAD Files

NC (1/4") - Without manual operator (V0) - Stainless Steel Seat (9DF/9DG/9DH/9DJ/9DP/9DQ)

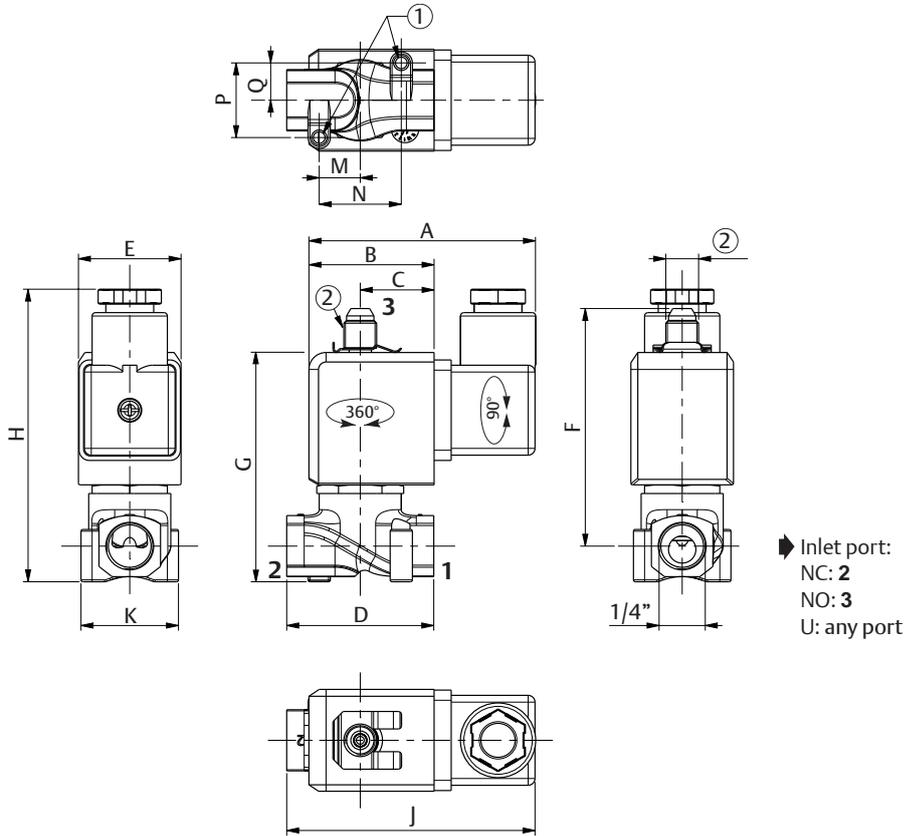

- ① 2 mounting holes:
M4 dia., through holes (0.16 inch dia.)
- ② 1/8" threaded

size 30		A	B	C	D	E	F	G	H	J	K	M	N	P	Q	weight ⁽¹⁾	
G356C119..G356C132	mm	66.3	36.6	21.6	43	30	70	81	86.7	72.6	28.5	12	24	22	11	0.3	kg
G356C214 / G356C219																	
G356C301..G356C311																	
8356C119..8356C132	(in)	2.61	1.44	0.85	1.69	1.18	2.75	3.18	3.41	2.86	1.12	0.47	0.94	0.87	0.43	0.66	(Lbs)
8356C214 / 8356C219																	
8356C303 / 8356C309																	

⁽¹⁾ Incl. coil(s) and connector(s).



Butler & Land Technologies

Butler & Land, Inc. is a manufacturer representative and distributor with extensive experience in the distribution and application of electrical equipment, instrumentation, controls and sensors to industrial and utility providers for over 70 years. Some of the industries we provide service to include, but are not limited to; food/beverage, water utilities, refineries, petrochemical plants, OEM's and electrical utilities.

www.butlerandland.com

Dallas, Texas

214-343-8800

10823 Sanden Dr, Dallas, TX 75238

Houston, Texas

713-896-0808

10900 Brittmoore Park Dr J, Houston, TX 77041

New Orleans, Louisiana

504-734-8888

1508 Edwards Ave. Suite GG, Harahan, LA 70123