

Features

- Compact Spool Valve convertible from 3/2 to 5/2 with flow plates
- Mount directly to actuators with NAMUR interface per VDI/VDE 3845
- Single and dual solenoid constructions available
- Integral Breather Block vents to spring side of actuator to exhaust, preventing corrosion of the actuator
- Unique design combines hard T-seals and flexible o-rings, provides bubble-tight shutoff, resistance to dirt and multimillion cycle life controlling air or inert gas
- Low Power and Intrinsically Safe construction available
See Special Service Pilot Valve Section for details

Construction

Valve Parts in Contact with Fluids			
Body	Aluminum, Black Anodized	Brass	316L Stainless Steel
End Cover (Spring end)	Glass-filled Polyamide	Brass	316L Stainless Steel
Spool Valve Internals	Zamak, Stainless Steel, Acetal (POM), Aluminum	Brass, Acetal (POM), Delrin	
Pilot End Covers	Aluminum, Black Anodized	Brass	316L Stainless Steel
Core Tube	Stainless Steel		
Core and Plugnut	Stainless Steel		
Springs	Stainless Steel		
Seals and Discs	NBR		
Top Disc	Nylon (PA)		
Core Guide	Acetal		
Seat and Seat Insert	Brass, Acetal		
Shading Coil	Copper		
Rider Ring (low power)	PTFE		

Electrical

Standard Coil and Class of Insulation	Watt Rating and Power Consumption				Spare Coil Part Number			
	DC Watts	AC			General Purpose		Explosionproof	
		Watts	VA Holding	VA Inrush	AC	DC	AC	DC
F	11.6	10.1	25	50	238610	238710	238614	238714

Standard Voltages: 24, 120, 240, 480 volts AC, 60 Hz (110, 220 volts AC, 50 Hz).
 6, 12, 24, 120, 240 volts DC. Must be specified when ordering.
 Other voltages are available when required.

Solenoid Enclosures

Standard: Watertight, Types 1, 2, 3, 3S, 4, and 4X.

Optional: Explosionproof and Watertight, Types 3, 3S, 4, 4X, 6, 6P, 7, and 9.
 (To order, add prefix "EF" or "EV" for stainless steel) to catalog number.)

See Optional Features Section for other available options.

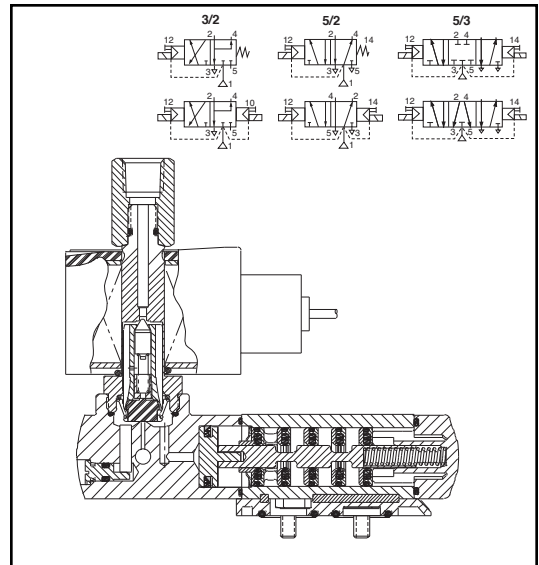

VALVE AUTOMATION

Nominal Ambient Temp. Ranges

Body Material	Description
Aluminum	AC: 5°F to 125°F (-15°C to 52°C) DC: 5°F to 104°F (-15°C to 40°C)
Brass	AC: -40°F to 125°F (-40°C to 52°C)
Stainless Steel	DC: -40°F to 104°F (-40°C to 40°C)

Approvals

UL/CSA approvals for aluminum constructions pending. EF and EV are UL listed solenoids. CSA certified. Meet applicable CE directives.
 SIL 3 capable per IEC 61508 on normally closed single solenoid. Third party certification provided by EXIDA.
Refer to Engineering Section for details.

ATEX/IECEx certified with prefix "EV" as listed. *Refer to Optional Features Electrical Section for details.*

Specifications (English units)

Body Material	Pipe Size (in)	Orifice Size (in)	Cv Flow Factor	Single Solenoid – PFD _{AVG} = 3.3 x 10 ⁻³						Dual Solenoid											
				Operating Pressure Differential (psi)			Max. Fluid Temp. °F			Catalog Number	Const. Ref.	Operating Pressure Differential (psi)			Max. Fluid Temp. °F			Catalog Number	Const. Ref.	Watt Rating/ Class of Coil Insulation	
				Air-Inert Gas			Temp. °F					Air-Inert Gas			Temp. °F					AC	DC
				Min.	Max. AC	Max. DC	AC	DC	AC	DC	Min.	Max. AC	Max. DC	AC	DC	AC	DC	AC	DC		
Aluminum 3/2, 5/2	1/4 ①	1/4	.86	30	150	120	140	120	8551G401	1	30	150	120	140	120	8551G402	1	10.1/F	11.6/F		
Aluminum 5/3 Center Closed									-	2						8551G465	2				
Aluminum 5/3 Center Open									-	2						8551G466	2				
Brass 3/2, 5/2									EF8551G403 ②	1						EF8551G404 ②	1				
316L Stainless Steel 3/2, 5/2									EV8551G409 ③④	2						EV8551G410 ③④	2				
Aluminum 3/2, 5/2									8553G401	2						8553G402	2				

① 1/8 inch NPT exhaust for aluminum and brass. ② Brass construction supplied standard with EF solenoid. ③ Stainless steel construction supplied standard with EV solenoid.
 ④ ATEX/IECEx certified with prefix "EV".

Specifications (Metric units)

Body Material	Pipe Size (in)	Orifice Size (mm)	Kv Flow Factor (m3/h)	Single Solenoid – PFD _{AVG} = 3.3 x 10 ⁻³						Dual Solenoid											
				Operating Pressure Differential (bar)			Max. Fluid Temp. °C			Catalog Number	Const. Ref.	Operating Pressure Differential (bar)			Max. Fluid Temp. °C			Catalog Number	Const. Ref.	Watt Rating/ Class of Coil Insulation	
				Air-Inert Gas			Temp. °C					Air-Inert Gas			Temp. °C					AC	DC
				Min.	Max. AC	Max. DC	AC	DC	AC	DC	Min.	Max. AC	Max. DC	AC	DC	AC	DC	AC	DC		
Aluminum 3/2, 5/2	1/4 ①	6.4	.7	2	10	8.2	60	48	8551G401	1	2	10	8.2	60	48	8551G402	1	10.1/F	11.6/F		
Aluminum 5/3 Center Closed									-	2						8551G465	2				
Aluminum 5/3 Center Open									-	2						8551G466	2				
Brass 3/2, 5/2									EF8551G403 ②	1						EF8551G404 ②	1				
316L Stainless Steel 3/2, 5/2									EV8551G409 ③④	2						EV8551G410 ③④	2				
Aluminum 3/2, 5/2									8553G401	2						8553G402	2				

① 1/8 inch NPT exhaust for aluminum and brass. ② Brass construction supplied standard with EF solenoid. ③ Stainless steel construction supplied standard with EV solenoid.
 ④ ATEX/IECEx certified with prefix "EV".

Dimensions inches (mm)

Series	8551
NPT	1/4
L1 ①	4.96 (126)
L2 ①	6.50 (165)
H2	4.38 (111)
H1	1.57 (40)
W	1.77 (45)

① Manual override option MH adds .250" (6.4), MS option adds .468" (11.9) to each solenoid endcap.

Optional Manual Operators		
Add Suffix		Description
MO		Push and turn to lock with flat head screwdriver slot
MI		Momentary push in with flat head screwdriver slot
MH		Momentary push in by hand
MS		Push and turn to lock by hand

Series	8551 (5/3)	8553
NPT	1/4	1/2
L1 ①	-	7.09 (180)
L2 ①	7.44 (189)	8.85 (225)
H2	4.38 (111)	4.77 (121)
H1	1.57 (40)	2.08 (53)
W	1.77 (45)	2.87 (73)

① Manual override option MH adds .250" (6.4), MS option adds .468" (11.9) to each solenoid endcap.

Optional Manual Operators		
Add Suffix		Description
MO		Push and turn to lock with flat head screwdriver slot
MI		Momentary push in with flat head screwdriver slot
MH		Momentary push in by hand
MS		Push and turn to lock by hand

Const. Ref. 1

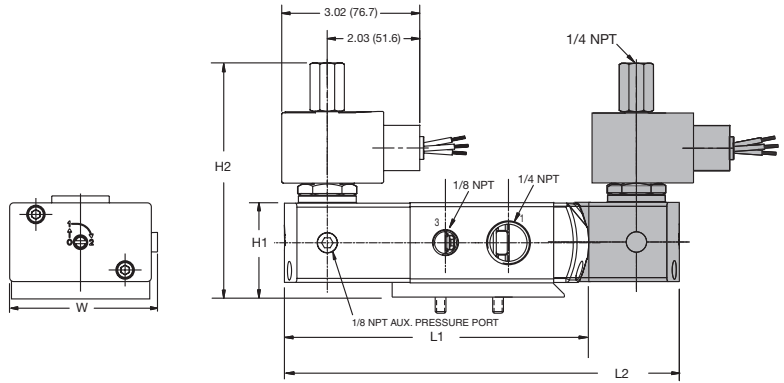

8551 NAMUR Footprint

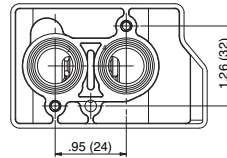

Const. Ref. 2

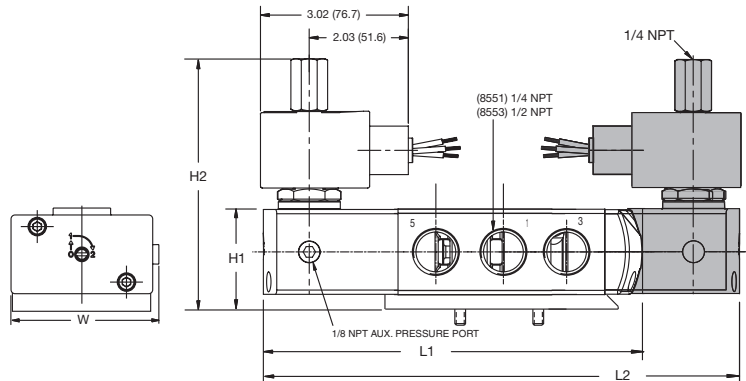

8553 NAMUR Footprint

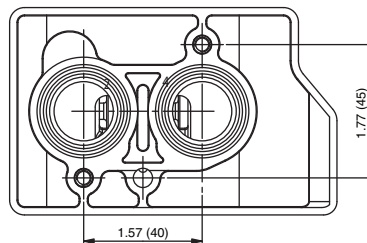

8551 NAMUR Footprint

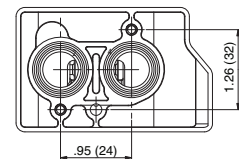



Butler & Land Technologies

Butler & Land, Technologies is a manufacturer representative and distributor with extensive experience in the distribution and application of electrical equipment, instrumentation, controls and sensors to industrial and utility providers for over 70 years. Some of the industries we provide service to include, but are not limited to; food/beverage, water utilities, refineries, petrochemical plants, OEM's and electrical utilities.

www.butlerandland.com

Dallas, Texas

214-343-8800

10823 Sanden Dr, Dallas, TX 75238

Houston, Texas

713-896-0808

10900 Brittmoore Park Dr J, Houston, TX 77041