

ASCO™ Solenoid Valves

For Low Pressure Gas, EN 161

Direct Operated, Hung Diaphragm, 3/8" and 1/2" threaded

2/2 NC
Series
215

Features and Benefits

- Valves for the control of gases on industrial atmospheric and forced draught burners
- All valves have been type tested to EN 161 and satisfy the Regulation (EU) 2016/426 on gas appliances
Certificate of conformity Kiwa Nederland B.V.: No. 0063AR1726
- All valves are for class A group 2 service and cover gas family 1 and 2
- Aluminium bodied valves designed to provide maximum flow
- The valves are for the control of low pressure gases compatible with the materials used
- The solenoid valves have a resilient soft seating for tight shut-off

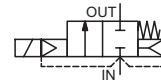

General

Differential pressure

0 - 2 bar [1 bar = 100 kPa]

Response time

25 - 120 ms

Fluids (*)	Temperature range (TS)	Seal materials (*)
combustible gas	-15°C to +60°C	NBR (nitrile)

Materials of components in contact with fluid

(*) Ensure that compatibility of materials in contact with fluids is verified.

Body	Aluminium
Core tube	Stainless steel
Core and plugnut	Stainless steel
Springs	Stainless steel
Seat	Aluminium or stainless steel
Seal, diaphragm and discs	NBR
Core guide	POM
Rider rings	PTFE
Shading coil	Copper

Electrical characteristics

Coil insulation class

F

Connector

Spade plug (cable Ø 6-10 mm)

Connector specification

ISO 4400 / EN 175301-803, form A

Electrical safety

IEC 335

Electrical enclosure protection

Moulded IP65 (EN 60529)

Standard voltages

AC (~): 24V - 48V - 115V - 230V / 50 Hz

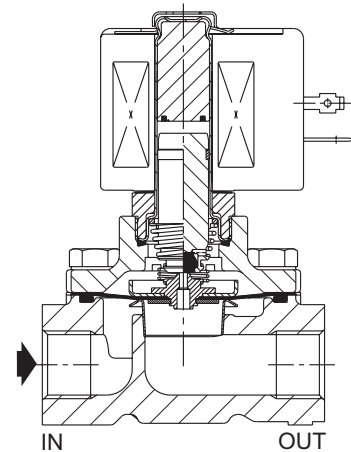

Prefix option	Power ratings			Operator ambient temperature range (TS) (C°)	Replacement coil ~	Type ⁽¹⁾
	Inrush	Holding				
	(VA)	(VA)	(W)			
EGSC	55	23	10.5	-15 to +60	400425-117	01

⁽¹⁾ For dimensions, see drawing(s) for each construction type on the following page(s).

00115GB-2021/R01 Availability, design and specifications are subject to change without notice. All rights reserved.



Specifications

Pipe size	Orifice size	Flow coefficient Kv ⁽¹⁾		Operating pressure differential (bar)		Power coil (W)	Catalogue number
				Min.	Max. (PS)		
Rp	(mm)	(m ³ /h)	(l/min)		Gas (*)	~	~
NC - Normally closed							
3/8"	19	2.9	48.3	0	2	10.5	EGSCE215B010
1/2"	19	3.8	63.3	0	2	10.5	EGSCE215B020

(1) For 2.5 mbar pressure drop air 1.0 s.g. at 1.013 bar and 15°C.

(*) Ensure that compatibility of materials in contact with fluids is verified.

Gaz Flow Chart

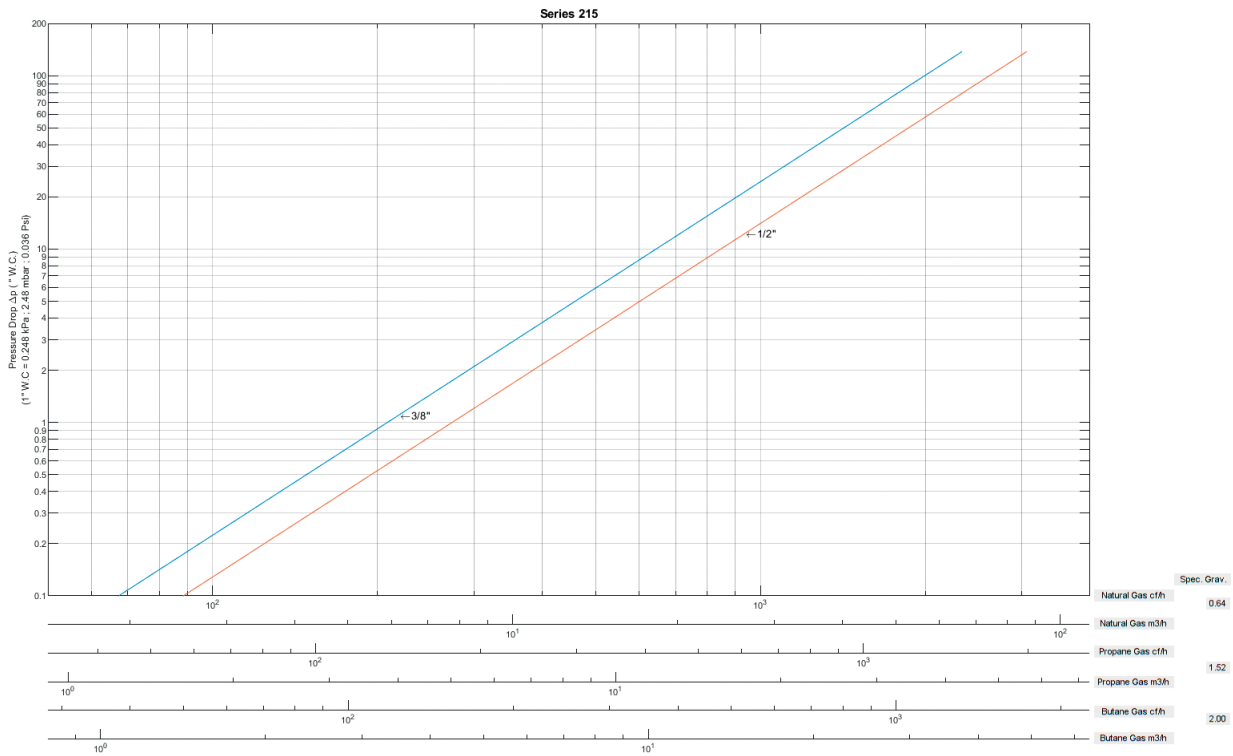

00115GB-2021/R01
Availability, design and specifications are subject to change without notice. All rights reserved.

ASCO™ Solenoid Valves

Options

- Mounting brackets, suffix MB
- Connector with visual indication and peak voltage suppression or with cable length of 2 m

Installation

- The solenoid valves can be mounted in any position without affecting operation
- Pipe connection identifier is E = Rp (ISO 7/1)
- Installation/maintenance instructions in multiple languages are available on our website

Spare parts kit

Catalogue number	Spare parts kits no.	Mounting bracket no.
	~	
EGSCE215B010	C131447	038713-000
EGSCE215B020		

- Not available.

Ordering Examples Valves:

EGSC	E	215 B 010	230V / 50 Hz
EGSC	E	215 B 020	115V / 50 Hz

prefix — pipe thread — basic number — voltage — suffix

Ordering Examples Kits:

C131447

basic number —

Dimensions (mm), Weight (kg)



TYPE 01
Prefix "EGSC" Solenoid
Epoxy moulded
IEC 335 / ISO 4400
IP65

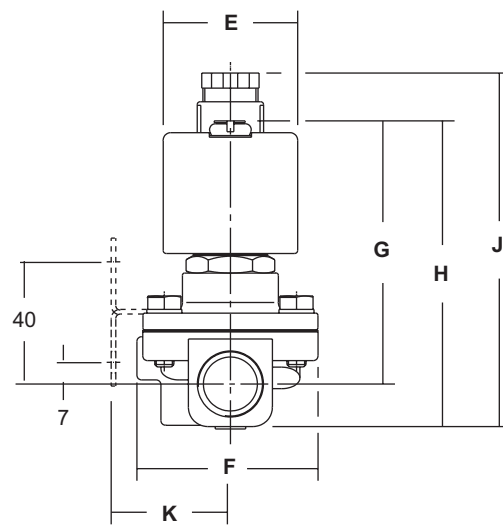
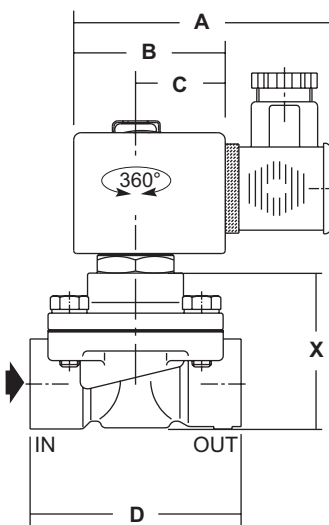

Mounting bracket

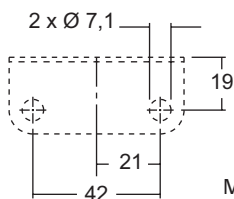
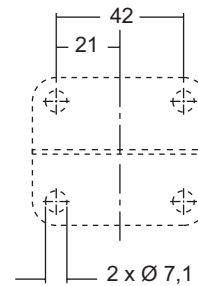

Mounting bracket

Type	Catalogue number	A	B	C	D	E	F	G	H	J	K	X	Weight ⁽¹⁾
01	EGSCE215B010 / EGSCE215B020	85	50	30	70	45	60	85	100	117	41	50	0.6

⁽¹⁾ including coil and connector.



Butler & Land Technologies

Butler & Land, Technologies is a manufacturer representative and distributor with extensive experience in the distribution and application of electrical equipment, instrumentation, controls and sensors to industrial and utility providers for over 70 years. Some of the industries we provide service to include, but are not limited to; food/beverage, water utilities, refineries, petrochemical plants, OEM's and electrical utilities.

www.butlerandland.com

Dallas, Texas

214-343-8800

10823 Sanden Dr, Dallas, TX 75238

Houston, Texas

713-896-0808

10900 Brittmoore Park Dr J, Houston, TX 77041